



# Prime 95B™

## Scientific CMOS

### Back Illuminated Scientific CMOS

#### Discovery depends on every photon

The Prime 95B is the Scientific CMOS with extreme sensitivity using high Quantum Efficiency (QE) Backside Illumination (BSI), a first for Scientific CMOS cameras. The Prime 95B's sensor converts up to 95% of incident photons into a measurable signal. Unlike microlens approaches to increasing QE, which lose effectiveness as objective magnification is increased, the Prime 95B's sensor brings light into the pixel photodiode from behind, avoiding structures that reflect or absorb light. When combined with large 11µm pixels, the Prime 95B can deliver over 300% more signal than other sCMOS cameras at 100X magnification.

More importantly, the Prime 95B outperforms EMCCD cameras—with no excess noise that negates the benefit of using a high QE sensor, and additional limitations from EM gain calibration, stability, expense, and sensor lifetime. With a true 16-bit dynamic range, the Prime 95B easily accomplishes what EMCCD can not—detect weak and bright signals within the same image with photon-noise limited performance.

The extreme sensitivity not only allows fainter signals to be detected, it provides the flexibility to increase frame rates, or turn down the excitation intensity to reduce cellular photo-damage. Yet the Prime 95B maintains the same high frame rates, field-of-view and extremely low read noise that has made sCMOS so popular for live-cell imaging.



#### APPLICATIONS

- Super-Resolution Microscopy
- Confocal Microscopy
- Single Molecule Fluorescence
- Light Sheet Microscopy

#### FEATURES

#### BENEFITS

**High Quantum Efficiency**  
**95% Peak QE**

Maximizes ability to detect weak signals, enables short exposure times for high frame rates, minimizes phototoxicity across a wide range of wavelengths

**Large 11µm Pixel Size**

Maximize light collection while maintaining proper spatial sampling

**Extremely Low Read Noise**

Maximize your ability to detect faint fluorescence

**Fast Frame Rates**

Capture highly dynamic events with high temporal resolution

**Large Field of View**

Maximize the number of cells that can be tracked and monitored per frame

**Enhanced Dynamic Range**

Measure both bright and dim signal levels within the same image  
50,000:1 Dynamic Range (94 dB)

**Multiple Expose Out Triggering**

Control up to four light sources for multi-wavelength acquisitions

**SMART Streaming**

Faster acquisition rates with variable exposures, ideal for multi-probed live cell imaging  
Compatible with Multiple Expose Out Triggering

## INCLUDED

- Prime 95B Scientific CCD Camera
- PCIe Card/Cable
- Trigger Cable
- Power Supply
- Manuals and QuickStart Guide
- Performance and Gain Calibration Test Data

## ADDITIONAL ACCESSORIES

- Liquid Circulator
- Liquid Cooling Tubes

## SPECIFICATIONS

<b>Sensor</b>	GPixel GSense 144 BSI CMOS Gen IV, Grade 1 in imaging area
<b>Active Array Size</b>	1200 x 1200 pixels (1.44 Megapixel)
<b>Pixel Area</b>	11 $\mu$ m x 11 $\mu$ m (121 $\mu$ m <sup>2</sup> )
<b>Sensor Area</b>	13.2mm x 13.2mm, 18.7mm diagonal
<b>Peak QE%</b>	>95%
<b>Read Noise</b>	1.6e- (Median), 1.8e- (RMS)
<b>Full-Well Capacity</b>	80,000e- (Combined Gain), 4,500e- (High Gain)
<b>Dynamic Range</b>	50,000:1 (Combined Gain)
<b>Bit Depth</b>	16-bit (Combined Gain), 12-bit (High Gain)
<b>Readout Mode</b>	Rolling Shutter, Effective Global Shutter
<b>Binning</b>	2x2 (on FPGA)

## CAMERA INTERFACE

<b>Digital Interface</b>	PCIe, USB 3.0
<b>Lens Interface</b>	C-Mount
<b>Mounting Points</b>	2 x 1/4 20" mounting points per side to prevent rotation
<b>Liquid Cooling</b>	Quick Disconnect Ports

## COOLING PERFORMANCE

<b>Air Cooled</b>	-10°C @ 30°C Ambient, 2.9e-/pixel/second
<b>Liquid Cooled</b>	-25°C @ 30°C Ambient, 0.7e-/pixel/second

## TRIGGERING

<b>Input Trigger Modes</b>	<b>Trigger-First</b> Sequence triggered on first rising edge <b>Edge</b> Each frame triggered on rising edge <b>SMART Streaming</b> Fast iteration through multiple exposure times
<b>Output Trigger Modes</b>	<b>First Row</b> Expose signal is high while first row is acquiring data <b>Any Row</b> Expose signal is high while any row is acquiring data <b>All Rows</b> Effective Global Shutter - Expose signal is high when all rows are acquiring data
<b>Output Trigger Signals</b>	<b>Expose Out (up to four signals), Read Out, Shutter Out, Trigger Ready</b>



- Cameras optimized for application needs
- Flexible and customizable branding options
- Unique part number/Bill of Materials (BOM)
- Single driver platform supports a wide range of product offerings
- Strategically located global service centers
- Dedicated support from a focused OEM team

## FRAME RATE

(PCIe Interface)

Array Size	16-bit	12-bit
1200 X 1200	41	82
1200 X 512	96	192
1200 X 256	192	384
1200 X 128	384	768

## SPECTRAL RESPONSE

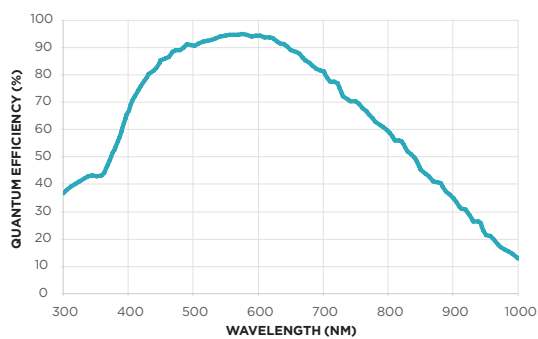

## DIMENSIONS

Distance from C-mount to sensor

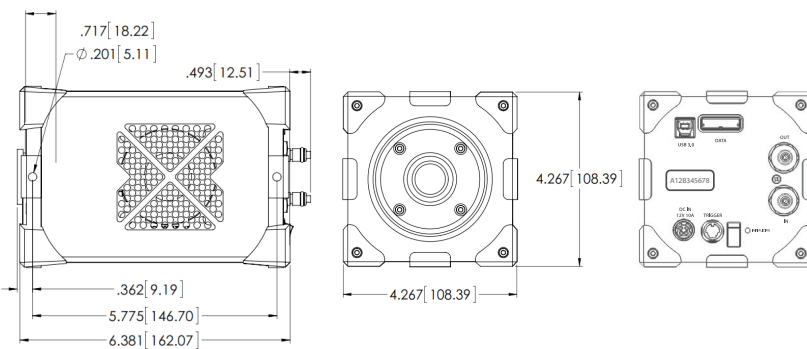

info@photometrics.com  
 www.photometrics.com  
 Telephone: +1 520.889.9933  
 Toll Free: +1 800.874.9789

Results are typical and may vary from camera to camera.

\*For more information, visit the Photometrics website at [www.photometrics.com](http://www.photometrics.com)

Note: Specifications are typical and subject to change.

Rev A0